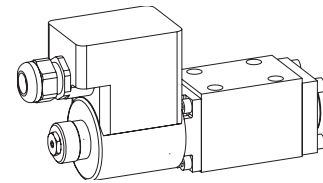

Proportional directional valve

- not pressure compensated
- $Q_{max} = 40$ l/min
- $Q_{Nmax} = 25$ l/min
- $p_{max} = 350$ bar

NG6
 ISO 4401-03

DESCRIPTION

Direct operated proportional spool valve in flange design NG6 acc. to ISO 4401-03/7790 with 4 ports. The spool valve is designed to the 5 chamber principle. The volume flow is adjusted by explosion proof proportional solenoid. Low pressure drop due to the body design and spool profiling. The spool is made of hardened steel. The body made of high grade hydraulic casting for long service life is painted.

EEx: in accordance with european standards EN 50014, EN 50019, EN 50028

e: increased safety

m: encapsulation

Group II:

for all applications except mining

Zone 1 / 21 (and 2 / 22):

explosive mixtures present intermittently

EC-type examination certificate:

PTB 01 ATEX 2129 X

FUNCTION

Proportionally to the solenoid current spool stroke, spool opening and valve volume flow will increase. Proportional directional valves NG6 are not load-compensated. The optimum spool shape and progressive characteristics curve allow fine motion control. To control the valve Wandfluh proportional amplifiers are available (see register 1.13).

APPLICATION

Proportional directional spool valves are well suited for demanding applications where high resolution, high volume flow and low hysteresis are requested. The facility for remote control and signal processing from process control systems enable elegant, comfortable solutions to problems. These valves are suitable for hazardous areas in off-shore and ship-building applications as well as in chemical, oil and gas industry.

CONTENT

GENERAL SPECIFICATIONS.....	1
HYDRAULIC SPECIFICATIONS.....	1
ELECTRICAL SPECIFICATIONS.....	2
TYPE CHARTS/ DESIGNATIONS OF SYMBOLS.....	2
CHARACTERISTICS.....	2/3
DIMENSIONS.....	4
PARTS LIST.....	4
ACCESSORIES.....	4

TYPE CODE

Proportional directional valve	WDC	F	A06	-	-	-	-	G24	/	#	
Flange construction											
International standard interface ISO, nominal size 6											
Description of symbols acc. to table 1.10-85/2											
Nominal volume flow Q_N : T4:	5 l/min	<input type="text" value="5"/>	T6:	3 l/min	<input type="text" value="3"/>						
(at 20 bar pressure drop)	10 l/min	<input type="text" value="10"/>		6 l/min	<input type="text" value="6"/>						
	16 l/min	<input type="text" value="16"/>		8 l/min	<input type="text" value="8"/>						
	25 l/min	<input type="text" value="25"/>		12,5 l/min	<input type="text" value="12,5"/>						
Standard nominal voltage U_N :	24 VDC										
Execution:	T1...T4	<input type="text" value="T4"/>	T1...T6	<input type="text" value="T6"/>							
Design-Index (Subject to change)											

GENERAL SPECIFICATIONS

Nominal size	NG6 acc. to ISO 4401-03/7790
Designation	4/2-, 4/3-way proportional directional valve
Construction	Direct operated spool valve
Mounting	Flange, 4 fixing holes for socket head cap screws M5x50
Fastening torque	$M_D = 5,5$ Nm (screw qual. 8.8)
Pipe connection	Connection plates Multi-station flange subplate Longitudinal stacking system
Mounting position	any, preferably horizontal
Admissible ambient temp. *:	
Execution T4	-20...+40 °C
Execution T6	-20...+70 °C (operation as T1...T4) -20...+40 °C (operation as T5/T6)
Weight:	4/2-way $m = 2,0$ kg 4/3-way $m = 3,0$ kg

HYDRAULIC SPECIFICATIONS

Fluid	Mineral oil, other fluid on request
Contamination	ISO 4406:1999, class 18/16/13
efficiency	(Required filtration grade $\beta_{6...10} \geq 75$) refer to data sheet 1.0-50/2
Viscosity range	12 mm ² /s...320 mm ² /s
Admissible fluid temp.*:	
Execution T4	-20...+40 °C
Execution T6	-20...+70 °C (operation as T1...T4) -20...+40 °C (operation as T5/T6)
Working pressure	$p_{max} = 350$ bar (connections P, A, B)
Tank pressure	$p_{max} = 160$ bar (connection T)
Nominal volume flow	T4: $Q_N = 5$ l/min, 10 l/min, 16 l/min, 25 l/min T6: $Q_N = 3$ l/min, 6 l/min, 8 l/min, 12,5 l/min
Max. volume flow	see characteristic
Leakage volume flow	on request
Hysteresis	T4: $\leq 5\%$ ** T6: $\leq 8\%$ ** ** at optimal dither signal

* Deviating pressure medium - or ambient temperatures are possible for special arrangements after checking and authorisation by a responsible inspector. Measures for the prevention of the exceeding of the admissible solenoid surface - and internal temperatures can be: a good ventilation, low ambient temperatures (for higher pressure medium temperatures), limitation of the maximum possible power supply voltage, a short switching-on duration, installation on large heat dissipating blocks, etc. The responsibility in all cases lies with the operator, resp. with his inspector.

ELECTRICAL SPECIFICATIONS

Construction Proportional solenoid, wet pin push type, pressure tight
Standard nominal voltage $U_N = 24$ VDC
 DC = Ripple 20%; wired with VDR
Limiting current T4: $I_G = 585$ mA
 T6: $I_G = 220$ mA
Relative duty factor 100% ED
Protection class IP65 / IP67 acc. to EN 60 529
Connection/Power supply Through cable entry for cable $\varnothing 6...12$ mm

Designation
Execution T4: II 2 G EEx em II T4 (for gas)
 II 2 D IP65 T130°C (for dust)
Execution T6: II 2 G EEx em II T6 (for gas)
 II 2 D IP65 T80°C (for dust)
Limiting wattage
Execution T4: 14 W at $I_G = 585$ mA
Execution T6: 5,8 W at $I_G = 220$ mA

START-UP

1. In the power supply for each solenoid a fuse of an appropriate rating (max. 3 times I_B of solenoid, DIN 41571 or IEC 127) respectively a motor circuit breaker with electromagnetic and thermal interruption must be installed. The fuse may be located in the power supply unit for the solenoid or between power supply and solenoid. The voltage rating for the fuse must be equal or higher than the one for the solenoid.

2. The solenoid coils must only be operated on the valve belonging to them. More information concerning the installation and commissioning is contained in the operating instructions supplied together with the solenoid coil.

TYPE CHARTS / DESIGNATIONS OF SYMBOLS

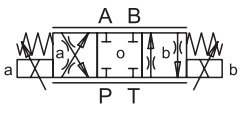
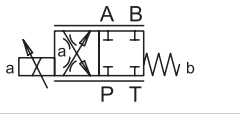
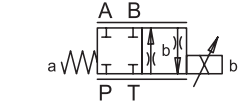
	ACB - S S = Symmetrical control mode
	AC1 - S S = Symmetrical control mode
	CB2 - S S = Symmetrical control mode

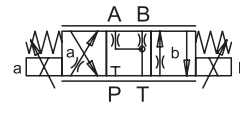
	ADB - V V = Meter-in control mode
--	---

CHARACTERISTICS oil viscosity $\nu = 30$ mm²/s

Q = f (p) Volume flow pressure characteristics ($l = l_G$)
 [Types: ACB-S, AC1-S, CB2-S]

Q = f (p) Volume flow pressure characteristics ($l = l_G$)
 [Type: ADB-V]

Q [l/min] Execution T4

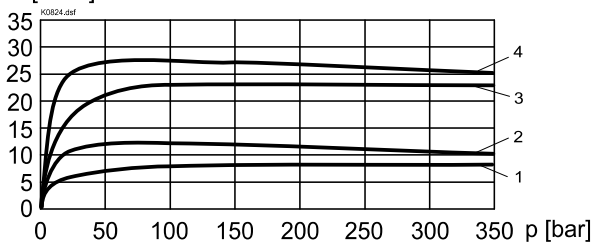

Q [l/min] Execution T4

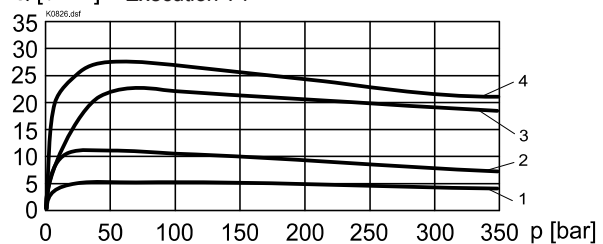

Q [l/min] Execution T6

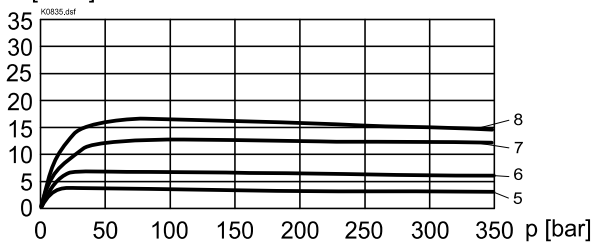

Q [l/min] Execution T6

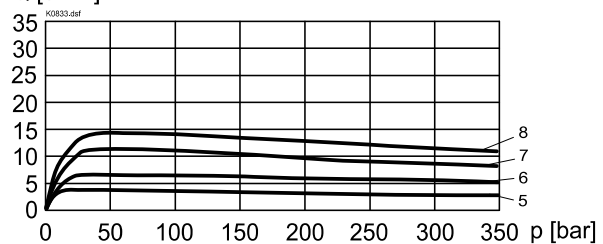

Legend:

1: $Q_N = 5$ l/min 5: $Q_N = 3$ l/min
 2: $Q_N = 10$ l/min 6: $Q_N = 6$ l/min
 3: $Q_N = 16$ l/min 7: $Q_N = 8$ l/min
 4: $Q_N = 25$ l/min 8: $Q_N = 12,5$ l/min

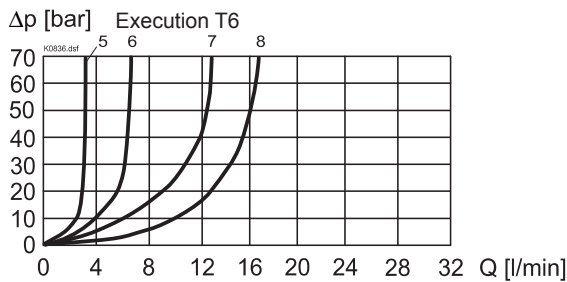
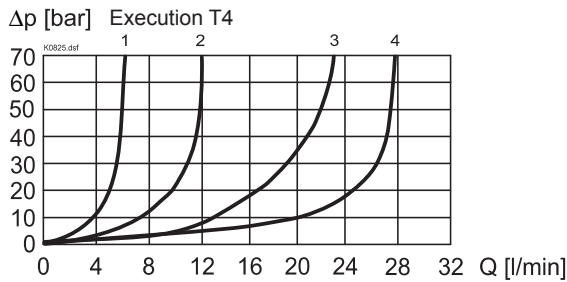

NOTE!

All values measured over 2 metering edges,
 A and B ports linked

$\Delta p = f(Q)$ Pressure loss/flow characteristics ($l = l_G$)
 [Types: ACB-S, AC1-S, CB2-S]

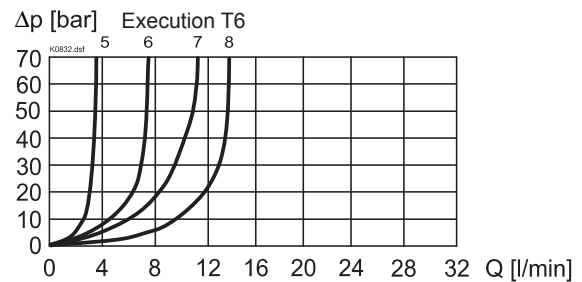
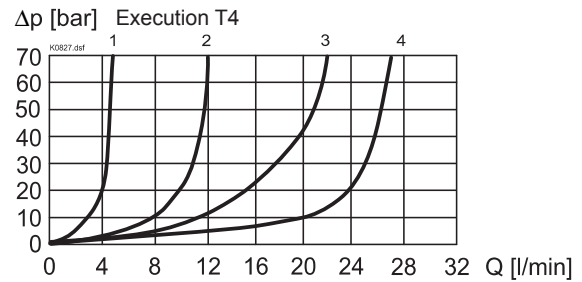

$\Delta p = f(Q)$ Pressure loss/flow characteristics ($l = l_G$)
 [Type: ADB-V]



$Q = f(l)$ Volume flow adjustment characteristics ($\Delta p = 20$ bar)
 [Types: ACB-S, AC1-S, CB2-S]

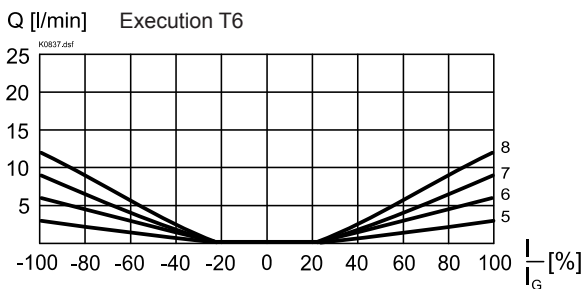
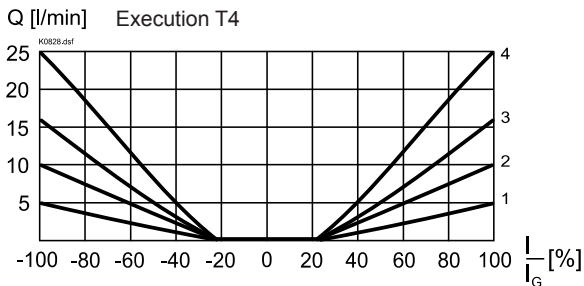

$Q = f(l)$ Volume flow adjustment characteristics ($\Delta p = 20$ bar)
 [Type: ADB-V]

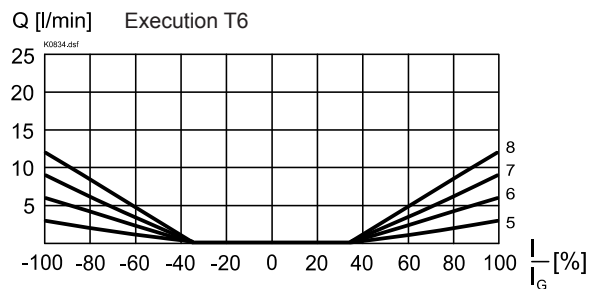
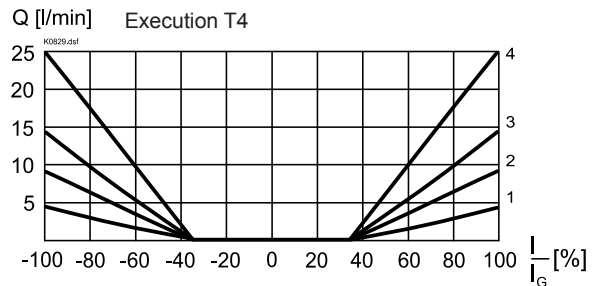

Legend:

- | | |
|---------------------|-----------------------|
| 1: $Q_N = 5$ l/min | 5: $Q_N = 3$ l/min |
| 2: $Q_N = 10$ l/min | 6: $Q_N = 6$ l/min |
| 3: $Q_N = 16$ l/min | 7: $Q_N = 8$ l/min |
| 4: $Q_N = 25$ l/min | 8: $Q_N = 12,5$ l/min |



NOTE!

All values measured over 2 metering edges, A and B ports linked



DIMENSIONS

4/3-way valve

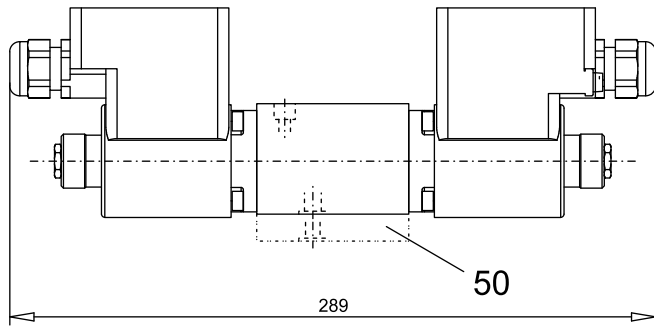

Order distance plate ADP6/12 separately

4/2-way valve

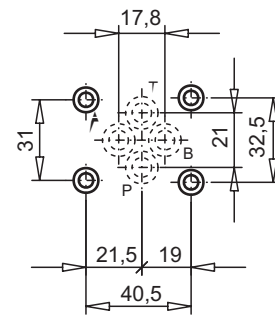
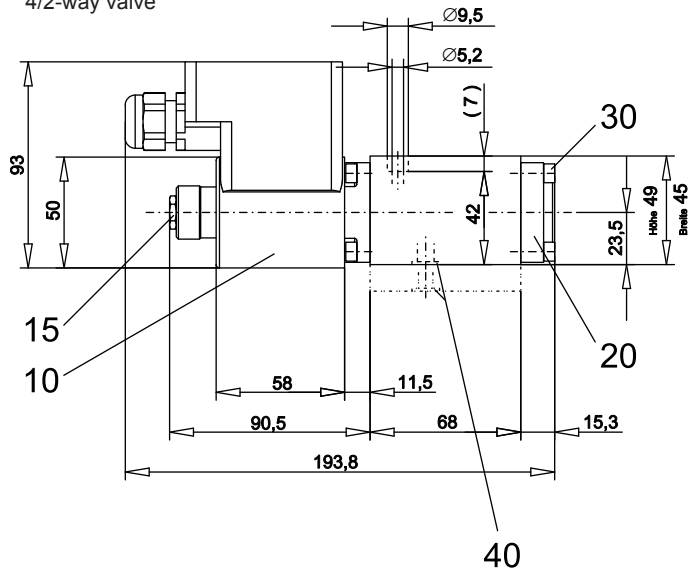
PARTS LIST

Position	Article	Description
10	207.5...	Coil type EExem
15	253.8001	Plug with integrated manual override HB6
20	058.4211	Cover
30	246.2117	Socket head cap screw M5x16 DIN 912
40	160.2093	O-ring ID 9,25x1,78
50	173.3451	Distance plate ADP6/12

ACCESSORIES

Sub-plates	Register 1.9
Proportional-amplifier	Register 1.13

Technical explanation see data sheet 1.0-100E

